

Key

- 1) Plot the following northings and eastings on the grid below:
 $A \frac{47.5}{33.0}$ $B \frac{61.5}{100.0}$ $C \frac{-15.0}{110.0}$ $D \frac{-40.0}{65.0}$ $E \frac{-40.0}{-35.0}$ $F \frac{-25.0}{-70.5}$ $G \frac{5.0}{-67.5}$ $H \frac{61.5}{-54.0}$
- 2) Connect the plotted points to create traverse A-B-C-D-E-F-G-H-A
- 3) Determine the latitude (change in northing) and departure (change in easting) between adjacent coordinates and use these figures to sketch triangles where the "hyp" is the traverse course, the "opp" side is the departure, and the "adj" side is the latitude. Calculate the bearing and distance for each course and record the data on the chart on the next page.

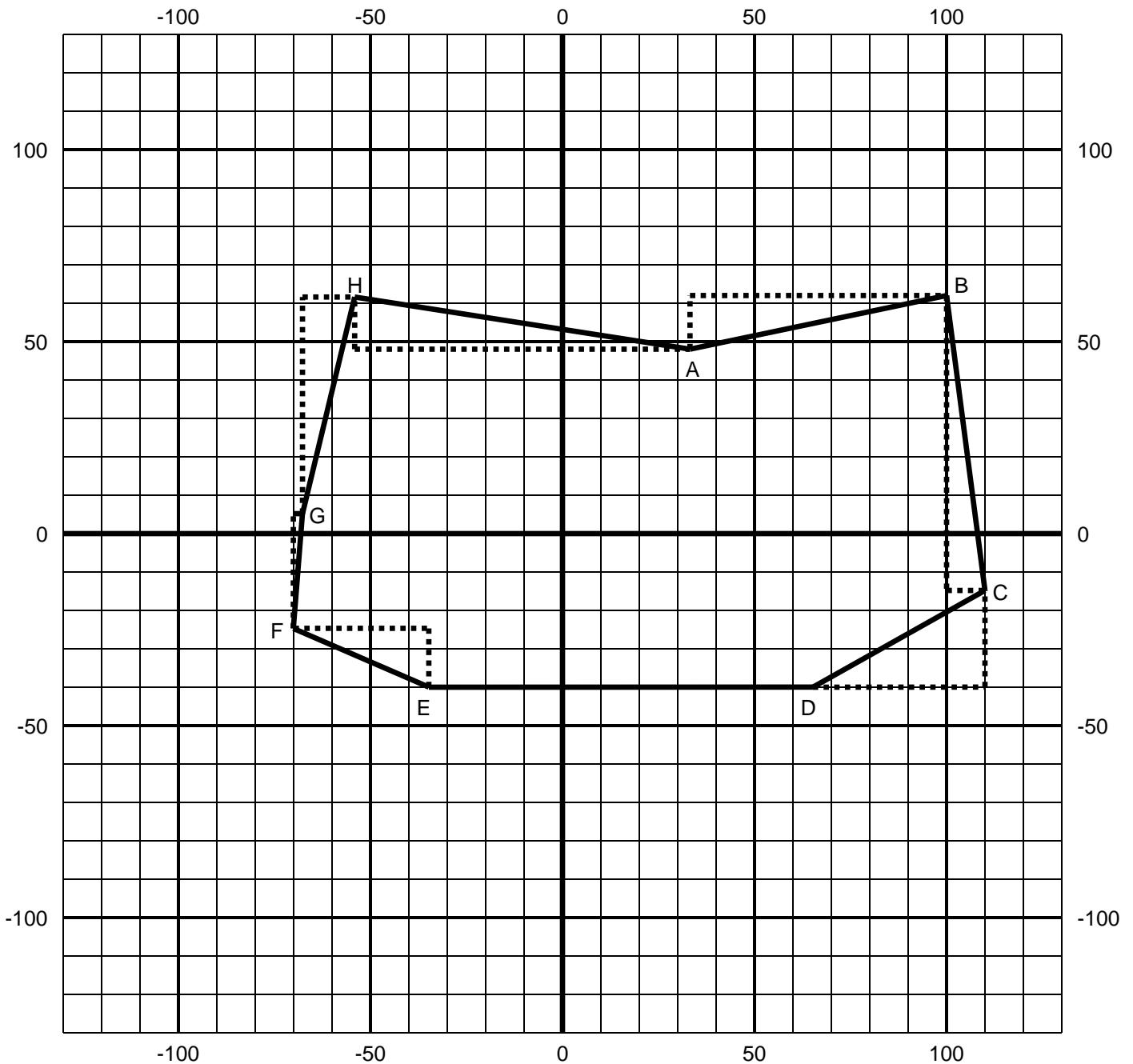

Key

STA	NORTHING	EASTING	LATITUDE	DEPARTURE	BEARING	AZIMUTH	DISTANCE
A	47.5	33.0					
			14.0	67.0	N 78-11-51 E	78-11-51	68.45'
B	61.5	100.0					
			-76.5	10.0	S 07-26-51 E	172-33-09	77.15'
C	-15.0	110.0					
			-25.0	-45.0	S 60-56-43 W	240-56-43	51.48'
D	-40.0	65.0					
			0.0	-100.0	WEST	270-00-00	100.00'
E	-40.0	-35.0					
			15.0	-35.5	N 67-05-39 W	292-54-21	38.54'
F	-25.0	-70.5					
			30.0	3.0	N 05-42-38 E	5-42-38	30.15'
G	5.0	-67.5					
			56.5	13.5	N 13-26-17 E	13-26-17	58.09'
H	61.5	-54.0					
			-14.0	87.0	S 80-51-30 E	99-08-30	88.12'
A	47.5	33.0					